



DESIGN AND DEVELOPMENT OF RC RAILED ROBOT FOR COFFEE NURSERY LOGISTICS

Marivic G. Dizon^{a,*}, Carlo T. Sevillano^a, Mark Anthony T. Cabaluna^a
^a Cavite State University, Indang, Cavite, 4122 Philippines

Received 09 September 2014; received in revised form 30 October 2014; accepted 02 November 2014
Published online 24 December 2014

Abstract

The Remote Controlled (RC) Railed Robot was designed and developed to transfer polybags from manual operation to an automated logistic system. Gizduino microcontroller was used to read and interpret commands sent and received by the transceivers to the robot and a remote to command instructions to the robot. The project was tested and evaluated at the Coffee Nursery of Cavite State University by determining the speed of the robot, the effectiveness of the remote control and the accuracy of the robot to lift a pallet and place it into an empty space. Results showed that the robot was able to receive and interpret commands provided by the remote control as well as perform the tasks successfully. The most significant recommendation was to use a counterweight at the rear side of the robot to avoid unnecessary derailments of the robot if lifting the heavier or greater number of pallets is desired.

Keywords: remote control, coffee nursery, gizduino microcontroller, automated logistic system.

I. INTRODUCTION

Coffee is one of the most valuable primary products in world trade, but coffee seeds grow slowly during cold weather. To achieve faster seed growth during this weather, the seed should be planted in a clear plastic or polyethylene bag and placed in a coffee nursery beneath a shade. The nursery includes the seedbeds or germination beds where the seeds are sown to germinate and produce seedlings as well as nursery beds where the seedlings are nurtured until they are ready for planting out in the field [1].

The existing method of nursery logistics in the Cavite State University coffee center is through manual operation. Since this type of method is very laborious and tedious, nursery logistics can be operated automatically using a remote controlled robot that navigates into a railway to overcome this kind of problem [2].

Several components such as microcontroller can be used for taking input from a device and control it by sending signals to different components in the system [3]; DC motors that uses electricity and a magnet to produce torque in order to turn the motor [4]; transceiver for transmitting and receiving data from a wireless communication [5]. Another component is

sensors that detect changes in a certain condition or in the state or another device [6].

The Remote Controlled (RC) railed robot was designed and developed to provide an alternative way of transferring polybags from manual operation to an automated logistic system for the coffee nursery. By developing a remote controlled robot, it would reduce the drudgery in moving seedlings from one location to another which is essential in reducing plant populations to account for canopy growth.

It was composed of microcontroller unit, DC motors, transceiver, sensors, and powered by a 12V power supply. The Gizduino microcontroller board reads and interprets commands sent and received by the transceivers to the robot. A remote control unit was used to command instructions the robot has to perform.

II. METHODOLOGY

This chapter involves the development and design perspective, the steps and procedures in the development of the remote controlled railed robot for coffee nursery logistics. This also covers dry-run and evaluation procedures and techniques to determine the acceptability of the system.

* Corresponding Author. Phone: +63-9173519855
E-mail: mavic_mgd2001@yahoo.com

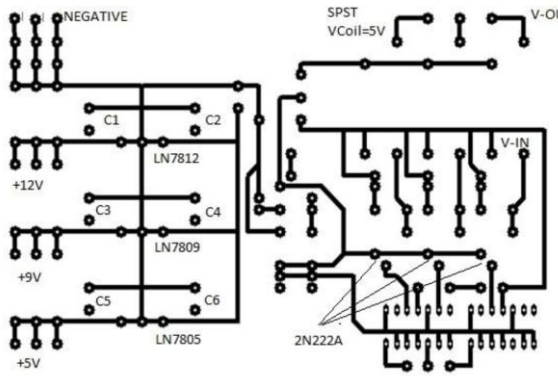

Figure 1. PCB layout of the microcontroller circuit

A. Design and Construction of Microcontroller Circuit

Two microcontroller units were used in the study, both of which were Arduino based, Gizduino ATMEGA328. The control unit served as the brain of the robot since it tells when to allow the execution of an operation. The circuit of the controller was first designed, set up and tested in a breadboard to check its operation. Pins and socket were used to prevent any damages in the testing. The design layout shown in Figure 1 was plotted in the PCB, after the circuit has been thoroughly developed and tested. The board was soaked in a developer solution until the layout becomes visible. The PCB was rinsed in water, fabricated, and tested for the continuity of every

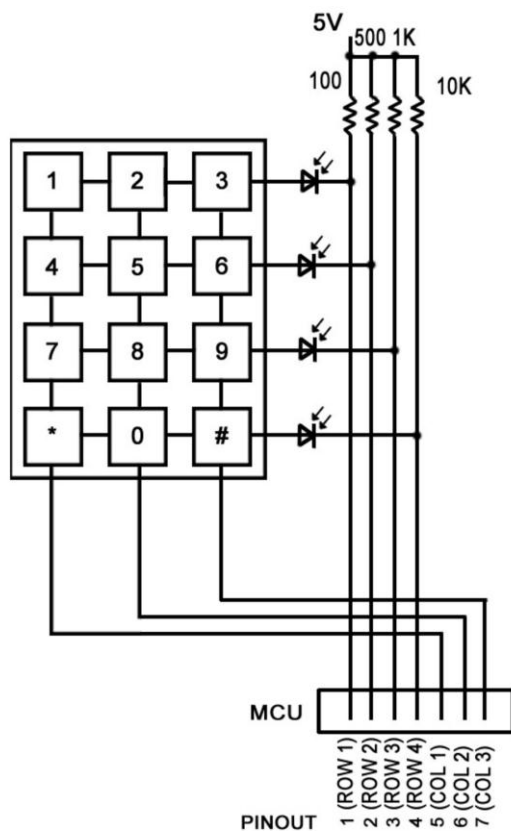

Figure 2. Keypad to the microcontroller unit configuration

line using a multimeter. When no errors are detected, the board was drilled according to the pin layout of the circuit and was soldered.

The microcontroller circuit has its own platform that was connected to the motor drivers, sensors, and motors. This included H-Bridge motor driver, relay boards that switched which motor would operate, a voltage regulator that regulates the output voltage from 12.9 and 5 V, ultrasonic and proximity sensors, wiper and power window motors. The microcontroller circuit was placed at the inner part of the robot to prevent the damage of components during the operation. Once all the units held together firmly, it was paired through connecting wires to the load cell and the direct current motors.

B. System Development

The remote control consisted of UHF data transceiver and microcontroller unit with 4x3 encoder circuit to have a unique identity of each value in the keypad. After determining the pin configurations of the data transceiver and identities of a keypad, the circuit layout for the remote control shown in Figure 2 was drawn on a tracing paper and was tested on a breadboard. The transparency films were drafted and attached on a double sided presensitized printed circuit board (PCB). The printed circuit board layout shown in Figure 3 was soaked and etched using a ferric chloride. All the necessary connections had been checked using a multi tester and perforated using a drill bit. The transmitter in the remote control transmits commands depending on the buttons pressed in the keypad which the RF receiver receives. The received command will be interpreted by the microcontroller.

The microcontroller then sends commands to the motors which serve as the output. Motor 1 controls the mobility of the robot. Motor 2 controls the rotation of the upper part of the robot

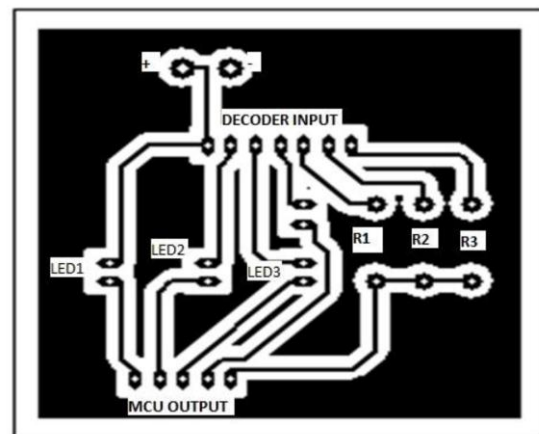

Figure 3. PCB layout of the remote control unit

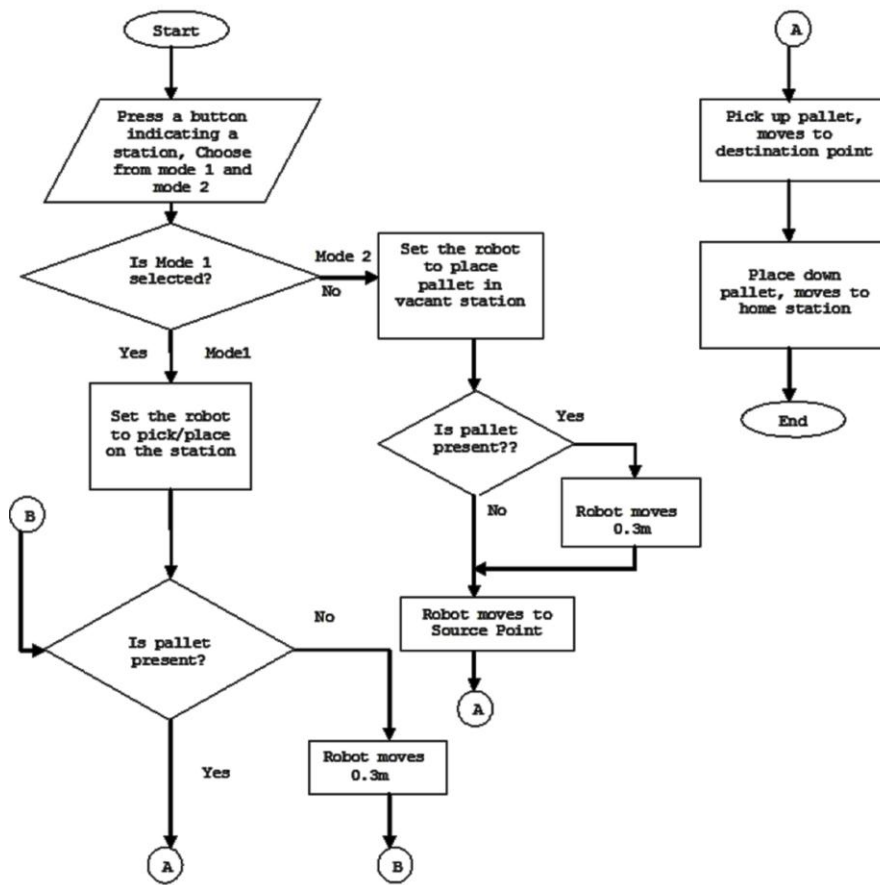

Figure 4. Program flowchart of the system

whether the input command would be to rotate to the left or rotate to the right side. It was then connected to three limit switches indicating the position of the pivot mechanism. Motor 3 was designated for the retraction of the fork lift. Motor 4 is for lifting and dropping of the pallets that contains polybags.

Ultrasonic sensor was used as an input to determine if a pallet is present in a station. It was placed at the bottom left and right of the device. The ultrasonic sensor and limit switch were directly connected to the digital input pins of the microcontroller and the data transceiver I/O pins were connected to Tx and Rx of the microcontroller and were programmed to function as a receiver.

Another transceiver interfaced to the second microcontroller was programmed to function as a transmitter. This was the remote control unit that emits the input signals that the main microcontroller unit receives. The motors were connected to the digital output pins of the microcontroller and responds according to the input signals received by the main microcontroller unit transmitted by the remote control unit.

C. Software Development

The system software was first designed in a flowchart which is necessary to present the step by step operation of the system as shown in Figure 4. The programs were checked for errors and debugged once error occurs and analysis was done to come up with an accurate program to control the operation of the system.

The software was programmed using the Arduino language. The remote control unit was programmed to have multiple buttons for eight stations, start and stop, and enter. The main microcontroller unit was programmed to control mobility of the robot and the function of the fork lift.

D. Design and Construction of the Railway for the Robot

Steel angle bars $\frac{3}{4} \times 1$ inch were used as the railway for the robot. It was placed inside the coffee nursery to designate stations for the robot. There were eight stations for the robot labeled as A to H and a base station which was labeled A where the robot stops after placing the pallet in its destination. The layout of the railway for the robot is shown in Figure 5.

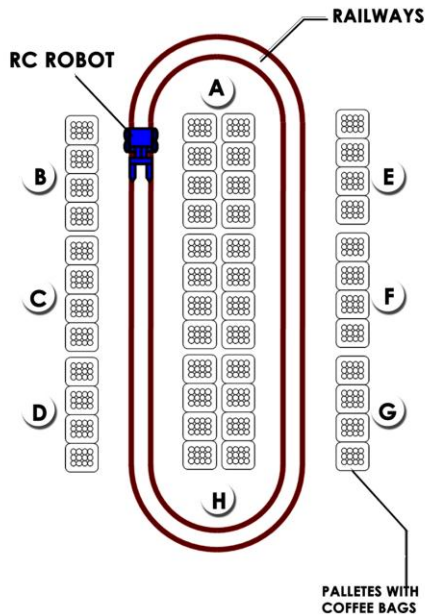

Figure 5. Nursery layout

E. Testing and Evaluation of the System

The system was tested and evaluated at the National Coffee Research Development and Extension Center of Cavite State University, Indang, Cavite by the faculty members of the Department of Computer and Electronics Engineering of Cavite State University, Indang. The system underwent a test run for a week to evaluate its function, capability, limitations and accuracy of the system to determine if the robot can execute the command from the remote control accurately. The strength of the forklift was also tested and evaluated to determine the number of polybags it can handle.

III. RESULTS AND DISCUSSION

This chapter presents the results of the study, analysis, and interpretation of data gathered with the end view of answering the research problem.

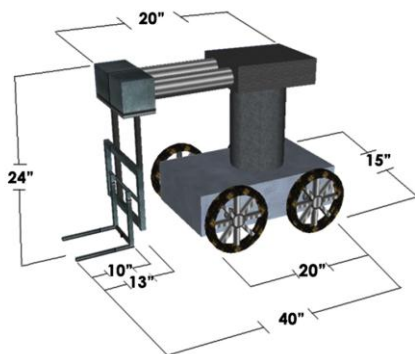

Figure 6. RC railed robot

A. Presentation and Analysis of Design

The remote controlled railed robot was designed mainly to be used in the National Coffee Research Development and Extension Center for coffee nursery logistics. Figure 6 shows embodiment of RC Railed Robot. The design project consisted of the following: small bike wheels, ultrasonic sensors, wiper motors, power window motors, infrared proximity anti-collision sensor, data transceiver, battery, h-bridge motor driver, and a microcontroller unit. Motor 1 controls the mobility of the robot. Motor 2 is for the rotation of the upper part of the robot. Motor 3 was designated for the retraction of the fork lift. Motor 4 is for lifting and dropping of the pallets. A remote control was also designed using the same microcontroller unit, a voltage divider used as an encoder, and a transceiver for the transmission of the commands.

B. Principles of Operation

The major function of the remote controlled railed robot is to transfer coffee seed bags from one place to another using the remote controller supplied by a 9 V rechargeable battery. Once the command is transmitted to the RF receiver, it will be interpreted by the microcontroller (see Figure 7). The battery will start to supply power to the main controller of the system which is Arduino ATmega328 with 40 mA output and the H-bridge motor driver with 50 mA output to the designated destination. An ultrasonic sensor placed at the left and right bottom of the robot will detect if a pallet is present or not. The presence of the pallet will trigger the 12 V wiper motor to rotate exactly 90 degrees using a limit switch indicating that it is the end of the arc. The infrared proximity-collision sensor will give a signal to the microcontroller if the lifting device is on its right position to lift a pallet. The retraction system will continue to move forward to its limit and the lifting device will lift a pallet containing

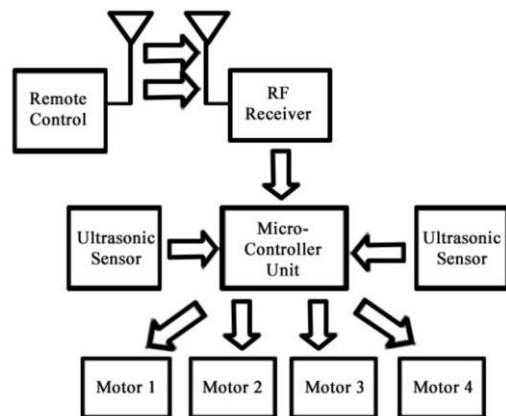

Figure 7. System block diagram

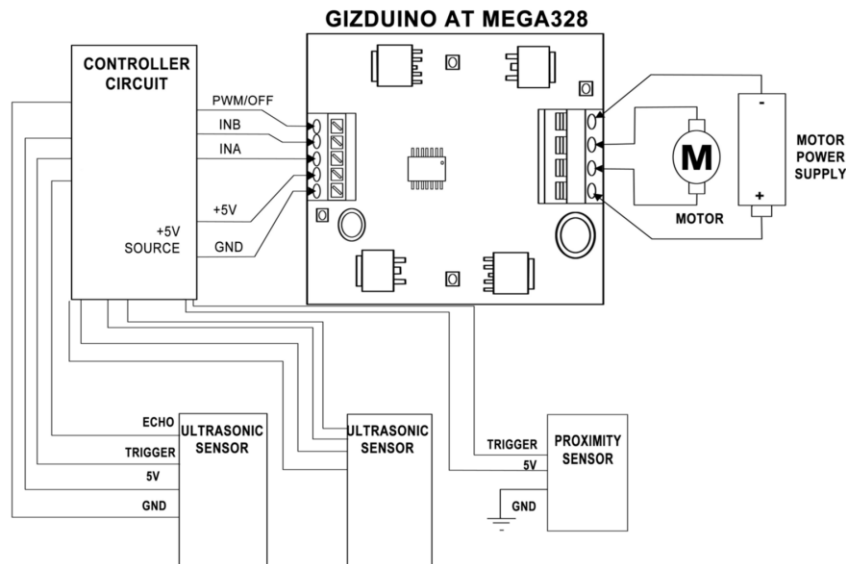

Figure 8. Microcontroller circuit wiring diagram

coffee seed bags. The system will continue until it reaches the desired destination and unloaded the pallets and goes back to the starting point.

C. Microcontroller Circuit

Figure 8 shows photo of the developed microcontroller circuit. The microcontroller circuits were composed of Gizduino ATMEGA 328 microcontroller unit where all the inputs and outputs are connected. At a conceptual level, when using the Arduino software stack, all boards are programmed over an RS-232 serial connection. The Arduino board exposes most of the microcontroller's I/O pins for use by other circuits. The H-bridge motor driver controller was connected to the digital input/output pins of the microcontroller. The control of the speed of the motor was connected to digital pin number 3. The directions of the motor were connected to digital pin numbers 6 and 7. Additional transistors and 5 volts contact triggering relays became the solution of the controller circuit. The output of the additional relays of the wiper motor and power window motor were connected to digital input/output pin number 12, 11, 10, 9, 8 and 5 depending on the motor that would function specifically. Ultrasonic sensors were used to detect the presence of the pallets. The trigger input of right and left bottom ultrasonic sonar sensor were connected to digital input/output pin numbers 4 and 8. The echo of the ultrasonic sonar sensor was connected to analog inputs A4 and A5. Limit switch was also used as an input to indicate that the pivot of upper mechanism is in 90 degrees and center position. It was connected to analog input A0 for its idle position. Analog input A1 was for pivot

left while analog input A5 was for pivot right position. Relays with 5 volts contact voltage triggers which motor would be used in a given command of a user.

D. Sensors for Detecting Pallets

Compact ultrasonic sonar sensors were used for detecting pallets. It was a low cost solution for circuit applications that requires distance measurements from an object, such as walls or any object that can bounce back the sound wave. User circuit initiates a measurement by driving the ultrasonic sensor trigger input to logic HIGH. In response, it will send short bursts of ultrasonic sound wave, and then outputs a pulse as soon as a returning echo is detected. The circuit resolves the distance by measuring the pulse width of the output pulse. Distances of up to 4.5 meters from the sensor can be measured with resolving resolution depending mainly on the user circuit.

Proximity collision sensor detects as far as 25 centimeters from the sensor face. Infrared beam makes it relatively insensitive to ambient light and color of target objects. Applications include non-contact object detection and collision sensor for mobile robots. It was used for accurate retraction of the forklift to the pallets.

E. Remote Control

Figure 9 shows the actual image of the remote control. The remote control of the robot consisted of a microcontroller unit, a voltage divider circuit, a transceiver, a 4 x 3 keypad with numbers from 1 to 0, a button for * and #, and an antenna. The identities of each pin of the keypads were identified using a voltage divider circuit. The microcontroller unit interprets the signal



Figure 9. Remote control of the robot

input from the keypad and transmits to the robot using the transmitter.

F. Software Description

The Arduino is a cross-platform application written in Java which is a C-based programming language used for the controller and receiver unit. Starting from check input on the transmitter, this checked the system when the input command to the remote controller was triggered. If input is greater than or equal to serial available 0, the led that connected to pin 13 would blink, otherwise it would not blink meaning the command was not interpreted.

In the receiver, if the data transceiver receives a signal coming from the transmitter, it would make the led in the pin 13 blink and checks if the received command is in Mode 1 or Mode 2. If Mode 1 is the input command, it would first check if the ultrasonic reading sensor is greater than or equal to 6,500. If yes, it would give High signal condition to motor1 telling it to move forward and search for available pallet. If the reading of the sensor is less than the given condition, it would not move forward. Motor 3 would activate for retraction, get a pallet, and gives a signal to Motor 1 to high condition indicating to move forward and search for a vacant place in the desired station. After putting the pallet in the vacant slot, it would go back to



Figure 10. The RC railed robot is transferring polybags.

its starting point. If mode 2 is activated, it would start to give signals to three motors to high conditions sequentially with the given delay to pick up a pallet first in the starting point then move the pallet in the vacant slot. If there is no vacant space sensed by the ultrasonic sensor, it would move forward and search for a space to drop a pallet. After the given condition of the input command is done, it would go back to initial position of the robot in the rail and wait for another input.

G. Testing and Evaluation

The evaluation and testing were conducted at the National Coffee Research Development and Extension Center, Cavite State University, Indang, Cavite. The time travel of the robot to its destination with a different number of polybags and the effectiveness of the remote-controlled robot operation were recorded. The range of wireless data transmission of the remote control was also evaluated to ensure that transmission of data is properly working. Figure 10 shows photo of the robot when transferring polybags.

The results of the evaluation are shown in the Table 1, Table 2, and Table 3. The data shown in Table 1, that the number of polybags increases, then, the time travel of the robot also increases. However, the feet per minute and meters per minute are decrease.

Table 1.
Speed of RC railed robot at 5 meters

No. of Polybags (1.5 kg each)	Time Travel (sec)	Speed	
		ft/min	m /min
0	23.2	70.8	21.6
1	24.3	67.5	20.5
2	25.9	63.2	19.3
3	27.9	58.7	17.9
4	31.7	51.7	15.8

Table 2.
Speed of RC railed robot at 10 meters

No. of Polybags (1.5 kg each)	Time Travel (sec)	Speed	
		ft/min	m /min
0	48.3	67.8	20.6
1	50.3	65.2	19.9
2	53.1	61.5	18.2
3	56.7	57.8	17.4
4	64.9	50.5	15.2

Table 3.
Speed of RC railed robot at 15 meters

No. of Polybags (1.5 kg each)	Time Travel (sec)	Speed	
		ft/min	m/min
0	71.6	68.7	20.9
1	74.8	65.8	19.7
2	80.3	61.3	18.5
3	85.7	57.8	17.9
4	94.2	52.2	15.2

As shown in Table 2, the time travel of RC railed robot to the destination became longer depending on the number of polybags carried in the pallet. The data obtained show that the number of polybags and time travel is inversely proportional to feet per minute and meters per minute. At 15 meters, Table 3 shows that increasing the number of polybags really affected the speed and time travel of the RC railed robot. Moreover, the data imply that the feet per minute and meters per minute of the robot decreases when time travel becomes longer.

The results have been shown by the test, the number of polybags increases in the pallet as the time travel to its destination becomes longer. The time travel and the speed are inversely proportional. The maximum number of polybags that the device can carry was four polybags with approximately 6 kilos in weight. If it increases its capacity, it would affect the performance and the balance of the RC railed robot and can cause to derailments.

H. Data Transceiver

A data transceiver is a device that is both a transmitter and a receiver which is combined and shares a common circuitry or a single housing. To examine the effectiveness of the data transceiver to the receiver unit, the remote control was tested in different distances several times. The rating used is shown in Table 4.

Table 4.
Reference for rating the accuracy of the remote control to the receiver unit

Rating	Description
5	Excellent – Exceeds the expected function of the robot.
4	Satisfactory – Meet all the functions of the robot.
3	Fair – Good enough for its use.
2	Needs improvement – Did not meet all the functions of robot
1	Poor – Not effective and no response from the receiver unit.

Table 5.
Effectiveness ratio of the remote control from the receiver unit

Distance (m)	Trials			Effectiveness (%)
	1 st	2 nd	3 rd	
10	5	5	5	100
20	5	5	4	93
30	1	5	5	73
40	1	5	3	60
45	1	1	3	40
50	0	0	0	0

Table 5 shows the results of the evaluation of the remote control in different distances. At 10 meters, the remote control successfully transmitted the commands to the RC robot. The expected function of the robot was achieved. At 20 meters, the robot did not complete the expected function at the 3rd trial. After rotating 90 degrees right, it stopped suddenly. The receiver unit during first trial at 30 meters did not respond. The command coming from the sender at 40 meters was not successfully transmitted during first and third trial. At 50 meters, the RC railed robot did not respond from any command. The actual range effectiveness achieved from the transmitter to the receiver was only approximately 45 meters with interference including nets, trees, poles and posts. Without any object blocking the signal of transmission, effective distance was 55 meters.

IV. CONCLUSION

The robot was able to receive and perform the commands that came from the remote control. The robot was operated through the use of a remote control. The desired station and the mode of either picking up or placing a pallet selected through the remote control were properly initiated. The robot was able to carry a pallet from either its left or right containing a maximum of four polybags weighing approximately 6 kilos at the speed of 0.157 meters/second. The robot could only receive a command coming from the remote control at a maximum distance of 44.09 meters with interference and in a clear field at 55 meters. The sensors used worked accurately in detecting the presence of a pallet and in aiming the fork to the pallet. The switch used determined the current station of the robot. The speed of the robot was around 20.6 – 21.6 m/min while carrying no polybags and was around 15.2 – 15.8 m/min while carrying four polybags. The effectiveness ratio of the robot to receive a command from the remote control at 10 m was 100 percent, 30 m 73 percent, and 0 percent

effectiveness at 50 m. The data implies that as the distance increase from the receiver, the effectiveness ratio decreases. Based on the results from the project, the following are highly recommended to enhance the device: enhancement of the infrared proximity sensor to an MK02 reed proximity switch for more accurate detection of a pallet containing polybags; and, use a counterweight at the rear side of the robot to avoid unnecessary lunging or derailments of the robot if lifting a heavier or greater number of pallets is desired.

ACKNOWLEDGEMENT

The Authors would like to thank Cavite State University for giving funds and allowing us to present the paper for international conference. Also, to all the concerned faculty members and staff of the College of Engineering and Information Technology for all the help and support that has been given.

REFERENCES

- [1] "About Coffee," International Coffee Organization, 2006. [Online]. Available: http://www.ico.org/coffee_story.asp?section=About_Coffee/ on April, 2012. [Accessed April 2012].
- [2] P. Baltzan, "Automation" Business Driven Technology, 2012.
- [3] M. Brain, "Microcontroller unit," 1998. [Online]. Available: <http://course.physastro.iastate.edu.pdf>.
- [4] M. H.W., "Cultivation and harvesting of the arabica coffee tree," *Coffee Agronomy*: Ed. R.J. Clarke, New York, 1998. [Online]. Available: [http://library.thinkquest.org/04oct/01639/light_en/science/plant/arabica/...](http://library.thinkquest.org/04oct/01639/light_en/science/plant/arabica/)
- [5] "Microcontrollers and Microcontrollers Information," Knightlight, 20000. [Online]. Available: <http://www.knightlight.com.uk>. [Accessed April 2012].
- [6] M. J., *Dictionary*, Prentice-Hall International, United Kingdom Limited, London England, 2000.
- [7] "Engineer on a Disk, A review on three technologies," 2012. [Online]. Available: http://engineeronadisk.com/V2/book_PLC/engineeronadisk-20.html/ .on May 2012.. [Accessed May 2012].
- [8] A. B. a. B. J. A. Malbino, *Digital Computer Eletronics 2nd Edition*, McMillan Inc., 1993.
- [9] E. H. Miller, "A note on reflector arrays," *IEEE Transmission Antennas Propagation* , 2012.
- [10] P. J. S. a. F. N., "What is DC motor," [Online]. Available: <http://www.wisegeek.org/what-is-a-DC-motor.htm..> [Accessed April 2012].
- [11] J. a. B. K. Seminara, "Electric forklift motor," 2012. [Online]. Available: <http://www.wisegeek.com/what-is-an-electric-forklift-motor.htm..> [Accessed April 2012].
- [12] S. J. a. F. N., "What are the different types of DC Motors?," 2012. [Online]. Available: <http://www.wisegeek.com/what-are-the-different-types-of-> [Accessed January 2012].