



Genetic algorithm-enhanced linear quadratic control for balancing bicopter system with non-zero set point

Esa Apriaskar^{a, *}, Dhidik Prastiyanto^a, Aryo Baskoro Utomo^a,
Akhyar Abdillah Manaf^a, Ilya Amelia^a, Dimas Alfarizky Ilham^a,
Viyola Lokahita Bilqis^a, Chonlatee Photong^b

^a Department of Electrical Engineering, Universitas Negeri Semarang
Building E8 UNNES Sekaran Campus, Gunungpati, Semarang City, Central Java 50229, Indonesia

^b Faculty of Engineering, Mahasarakham University
41, 20, Tambon Kham Riang, Amphoe Kantharawichai, Chang Wat Maha Sarakham 44150, Thailand

Received 22 August 2023; 1st revision 4 October 2023; 2nd revision 16 October 2023;
Accepted 20 October 2023; Published online 29 December 2023

Abstract

Bicopter is an unmanned aerial vehicle (UAV) with the advantage of saving energy consumption. However, the unique two rotors design presents a challenge in designing a controller that achieves good stability, fast settling time, and the ability to overcome oscillations simultaneously. This article proposes a new control method for bicopter that uses a genetic algorithm optimization approach in the linear quadratic (LQ-GA) control method. The GA is used to search for the best weighting matrix parameters, Q and R, in the Linear Quadratic (LQ) control scheme. The proposed control method was tested on a balancing bicopter test platform with an input in the form of difference in pulse width modulation (PWM) signals for both rotors and an output in the form of roll angle. The control system was evaluated based on the stability of the transient response and the generated control signal. The results of the tests showed that the proposed LQ-GA control method has better stability, faster settling time, and smaller overshoot than the existing PI and standard LQ control methods. Therefore, the proposed LQ-GA control method is the most suitable for use in a balancing bicopter system with a non-zero setpoint.

Copyright ©2023 National Research and Innovation Agency. This is an open access article under the CC BY-NC-SA license (<https://creativecommons.org/licenses/by-nc-sa/4.0/>).

Keywords: balancing bicopter; genetic algorithm; linear quadratic; roll angle; non-zero set point.

I. Introduction

The existence of UAV technology in our daily life has increasingly become prevalent. For its implementation, UAV can help people in terms of humanitarian relief [1], object monitoring [2], military purpose [3], and delivery operations [4]. In addition to their numerous advantages, UAVs encompass a diverse range of types based on the number of rotors, namely bicopter, tricopter, quadcopter, hexacopter, and octocopter. When comparing the flight time from the UAV classifications, the bicopter variant tends to be superior to other common rotor types [5]. This can be explained by a reduction in the number of rotors

can lead to lower unit power demand, which improves flight time and saves energy [6]. However, designing a controller for a bicopter can be challenging as it needs to stabilize the bicopter, reduce settling time, and overcome oscillation simultaneously [7]. Furthermore, it is still uncommon to find control methods developed in bicopter technology, particularly those that harness the assistance of artificial intelligence (AI).

In recent years, AI has become increasingly popular for solving a wide range of extensive problems, including improving controller performance [8]. With the use of AI in adjusting control parameters (tuning), the performance of a controlled system can achieve optimal conditions that can be seen from several parameters in transient response [9]. In the context of UAVs, previous studies have employed various controllers

* Corresponding Author. Tel: +62-248508104
E-mail address: esa.apriaskar@mail.unnes.ac.id

that perform quite well like the PID controller [10], pole placement [11], and LQ Control [12].

PID was used by [13] to produce a precise and quite inclusive attitude control architecture. In [14], PID control was implemented in a double-propeller type wall-climbing bicopter, which achieves attitude stability for low-speed operation. A PID control as demonstrated in [15], enables a bicopter platform to hover stably and carry significant payloads with efficiency rivaling that of a typical quadcopter. However, these studies still rely on empirical methods to determine the parameters, which can lead to high but not optimal results. In [16], the Ziegler-Nichols tuning method is applied to PID controllers which produce good settling time performance despite still having a high overshoot.

The other controller method as presented in [11] shows that a state feedback control method, pole placement control, produces a stable response on a bicopter although the determination of the K parameter was conducted analytically. On the other hand, LQ Control as one of the state feedback control methods is a superior option as it relies on optimization theory and is more robust compared to PID [17][18]. LQ Control can be utilized as an optimal controller to reduce the energy required to control UAV [19]. It is an optimal control method widely used to obtain state feedback gain (K) in addition to pole-placement methods [20]. LQ Control also offers a better solution to partially solve the issues. It can provide a control system that can reduce this issue by obtaining a K matrix from the Q and R matrix [17]. The optimal K parameters and reduction in the number of propellers will make the control signal in the bicopter system have low power consumption and longer flight time [21]. As shown in [22], the LQ Control implemented on the bicopter demonstrated asymptotic balance for roll angle despite still showing a high overshoot. Similarly, the quadcopter with LQ Control exhibits excellent stability without any steady-state errors [11]. However, it is worth noting that the study still employs analytical methods to determine the control parameters.

As one of the AI-based optimization techniques, Genetic Algorithm (GA) is considered capable of finding global optimal solutions [23]. It can be used to optimize the process tuning of LQ Control parameters in both the weighted Q and R matrix [24]. LQ Control which was optimized using GA was implemented for swarm control of UAV, though it is for quadcopters, instead of bicopters [25]. Another work mentioned in [26] also proves that GA managed to get the most optimal parameter of LQ Control. In [27], the combination of LQ Control and GA results shows a more optimal system response compared to LQ although it is applied to fixed-wing aircraft. In the case of bicopter, GA also proves to improve the control performance of the PID controller [21]. Since the GA and other control method collaboration especially LQ Control has been successfully implemented in the other technology case, there is a possibility that this method can be employed to control the attitude roll angle for a bicopter.

In this paper, we would like to examine the use of LQ Control as an optimal controller in the case of balancing bicopter control. It will generate an optimal K parameter which will be used as the controller gain for the bicopter. The performance will be compared with another LQ Control which is optimized by GA. It will also be compared to our proposed example published in [16] which applied a PI controller tuned by the Ziegler-Nichols method. We selected a PI controller because our previous work showed its superior performance over a PID controller in a comparable bicopter plant.

This paper organization is described as follows. The controlled plant along with the block diagram of the control system are presented in section II. The next section highlights the proposed methods including LQ Control and GA. Section IV presents the evaluation of the proposed methods using MATLAB simulation. It also covers the performance comparison between LQ Control and PI Controller. The last section gives the conclusion and potential future works that can be a new direction of the bicopter research.

II. Materials and Methods

A. Balancing bicopter control system

Balancing bicopter behaves by receiving inputs from two rotors situated at its two edges, as depicted in Figure 1. The lifting force produced by the airflow from the two rotors propellers allows it to balance itself. The roll angle (φ), which is the work's observed output, will force both rotors to move. The rotor speed at each end of the bicopter is controlled by the two rotors interaction, which produces a moment and an aerodynamic force.

M_B which is the moment to control the bicopter is stated in [16] and also expressed in equation (1). Equation (1) consists of several components namely the distance between the axis of rotation of the rotor and the center of mass of the vehicle (L), the constant of aerodynamic force (K_f), the constant moment (K_M), and the angular velocity of rotor that operate in bicopter (Ω_1 and Ω_2). Other than the dynamic model with rotor signal as the input and rotor angle as the output in [28], a transfer function has been constructed to illustrate the dynamics of

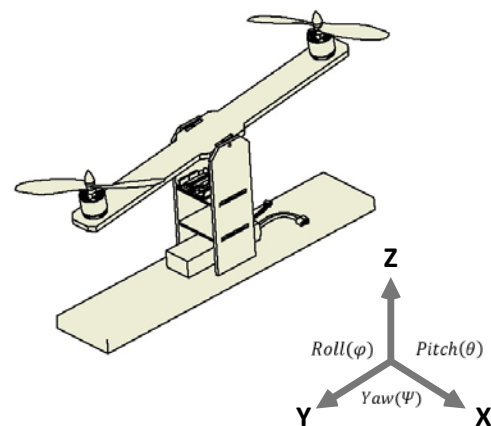

Figure 1. Bicopter design

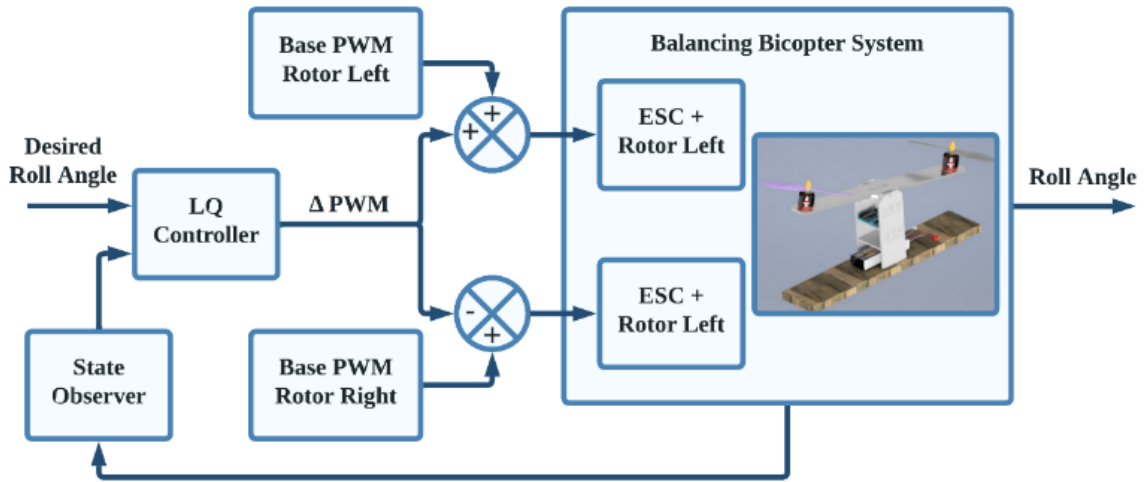

Figure 2. Bicopter system block diagram

balancing bicopter. The model was constructed using a multi-level periodic perturbation signal with φ as the input and a difference value of the PWM signals used to drive the rotors of the bicopter as the output. Several model structures were developed and assessed using a particular dataset distribution. This also establishes which model is most appropriate by examining their fittest value. Specific attention has been placed on a fourth-order transfer function as indicated in equation (2), especially regarding final validation with a feedback control approach.

$$M_B = \begin{bmatrix} LK_f(\Omega_1^2 - \Omega_2^2) \\ K_M(\Omega_1^2 + \Omega_2^2) \end{bmatrix} \quad (1)$$

$$\frac{\varphi(s)}{\Delta PWM(s)} = \frac{0.6126s^3 - 1.359s^2 + 28.81s + 5.315}{s^4 + 2.27s^3 + 19.89s^2 + 14.84s + 2.74} \quad (2)$$

Figure 2 shows the block diagram for balancing bicopter control. The calculated difference between the desired and actual values of the roll angle works as the controller's primary input. There will be two LQR controllers evaluated in this paper. The first one is the common LQR and the second one is the LQR that uses GA to obtain the controller parameter. The output of the controller is the PWM signal difference between the two rotors, which is then added to the

predetermined base PWM value of both rotors before being supplied to each electronic speed controller (ESC) of the rotors.

B. Linear quadratic control with non-zero set point

In this work, LQ Control is employed as the best controller to produce a K matrix that can track changes in the given set point. The system needs to be tracked to ensure that it remains the same value as the set point. This tracking is called a non-zero set point. This method can increase the dimensions of the matrix and the complexity of the design [29] Figure 3 illustrates the block diagram of the optimal control system in general.

Considering the block diagram, the plant model can be represented by equation (3) and equation (4).

$$\dot{x}(t) = Ax(t) + Bu(t) \quad (3)$$

$$Y(t) = Cx(t) + Du(t) \quad (4)$$

A, B, C, and D are representations of the model of a system in the form of a matrix. The whole matrix stands with the state itself ($x(t)$) and its inputs ($u(t)$) to affect the purposes, respectively. A and B govern the change in the state ($\dot{x}(t)$). Meanwhile, C and D directly influence the output ($Y(t)$)

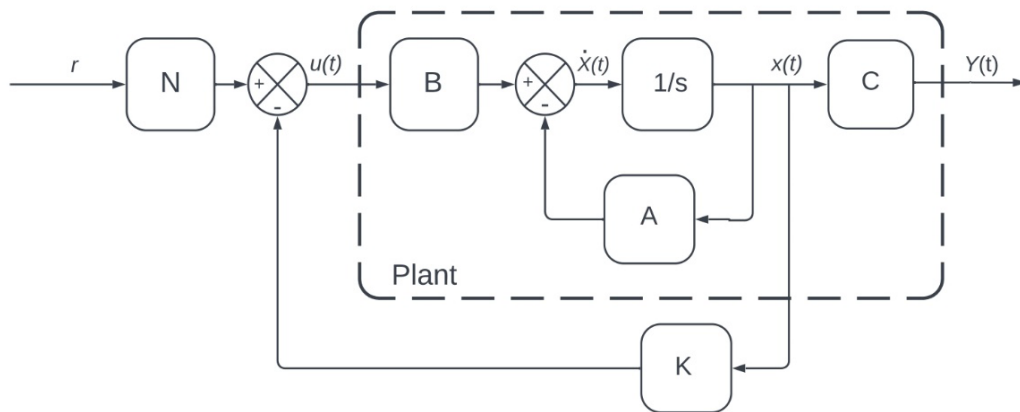

Figure 3. Linear quadratic control block diagram

Table 1.
Description of parameters

Parameter	Symbol	Unit
Roll angle	φ	$^{\circ}$ (degree)
Moment force	M_B	N
Distance between the axis of rotation rotor and the center of mass vehicle	L	m
Constant of aerodynamic force	K_f	-
Constant moment	K_M	-
Angular velocity of rotor 1	Ω_1	rad/s
Angular velocity of rotor 2	Ω_2	rad/s
Difference value of PWM signals for the rotors	ΔPWM	-
State matrix	A	-
Input matrix	B	-
Output matrix	C	-
Feedforward matrix	D	-
State vector	$x(t)$	-
Control input vector	$u(t)$	-
Output vector	$Y(t)$	-
Weight matrix for states	Q	-
Weight matrix for input	R	-
Feedback control gain	K	-
Reference gain	N	-
Set point value	r	-

The quadratic performance index is a measure of how well the control system is performing, which is a cost function in equation (5), and should be minimized in selecting to achieve the best control inputs along with optimizing the state variables

$$J = \frac{1}{2} \int_{t_0}^T \{x^T(t)Qx(t) + u^T(t)Ru(t)\} dt \quad (5)$$

where a positive semi-definite matrix is represented by Q and a positive definite matrix is represented by R. Q is responsible for setting the system's performance parameters so that it can be connected to the state vector system. The steady-state error will decrease as Q increases in value. While R is used to modify the input state so that the system can achieve gain. The x^T and u^T matrix represents the conjugates of the transpose results of the x and u matrix. Subsequently, equation (6) defines the performance index as a K matrix. The P component in equation (6) is a positive semidefinite solution to the Algebraic Riccati Equation (ARE) which needs to persuade as written in equation (7).

$$K = R^{-1}B^T P \quad (6)$$

$$A^T P + PA + Q - PBR^{-1}B^T P = 0 \quad (7)$$

The Q matrix determines the weighting of the state errors, which affects the system's performance and the setting of how much each state control will be adjusted. Proper prioritization of the state from the Q matrix can provide better control. The identity matrix can be applied to the Q matrix because of its nature that does not specialize in a certain state, thereby minimizing errors in all states in a balanced and simple way. Equation (8) is a Q matrix using the identity matrix.

$$Q = \begin{bmatrix} Q1 & Q2 & Q3 & Q4 \\ Q5 & Q6 & Q7 & Q8 \\ Q9 & Q10 & Q11 & Q12 \\ Q13 & Q14 & Q15 & Q16 \end{bmatrix} = \begin{bmatrix} Q1 & 0 & 0 & 0 \\ 0 & Q6 & 0 & 0 \\ 0 & 0 & Q11 & 0 \\ 0 & 0 & 0 & Q16 \end{bmatrix} \quad (8)$$

With the purpose of getting a good performance index, the implementation of the state feedback control laws is expressed in equation (9), where K is feedback control gain, N is reference gain defined in equation (10) and r is the set point value that has been determined.

$$u(t) = -Kx(t) + Nr \quad (9)$$

$$N = -[C(A - BK)^{-1}B + D]^{-1} \quad (10)$$

Obtained from the results of the substitution of equation (8) into equation (3) and equation (4), the closed loop system response can be found in the simulation as in equation (11) and equation (12). Table 1 provides a detailed explanation of the parameters used in this study.

$$\dot{x}(t) = (A - BK)x(t) + BNr \quad (11)$$

$$Y(t) = Cx(t) + DNr \quad (12)$$

C. Genetic algorithm optimization

Genetic algorithm (GA) is one of the earliest population-based stochastic algorithms to be proposed in history [30]. It used the study of natural selection as its method of operation which includes crossover, selection, and mutation before GA obtains the best individual as shown in Figure 4. Because of the use of natural selection as optimization's fundamental, GA is technically reliable and does not make any predictions about the search space. Without the need for any additional auxiliary data, it can manage the search using only the values of the objective function.

This work used GA as an optimization method to find the best Q and R parameters in a bicopter balancing system. Several parameters are required by GA before performing the natural selection process, as shown in Table 2. These parameters were determined using a trial-and-error approach, with the goal of minimizing computational time and

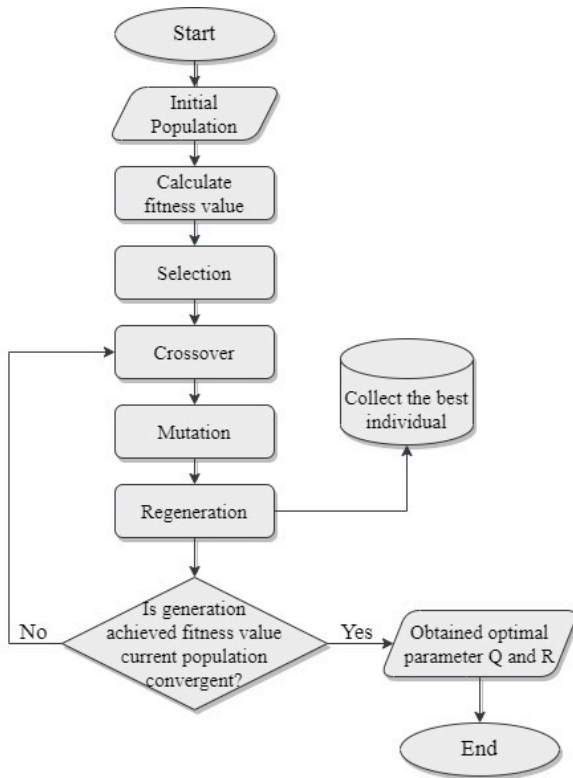

Figure 4. Genetic algorithm flowchart

expediting the convergence to optimal solutions. An initial population, also known as the first generation, is used as a base for the optimization of the Q and R matrix which has 4 and 1 individuals, respectively. Utilizing 150 populations, the first randomly generation is produced to obtain an objective function ($f_{i,G}$) that comes from integral absolute error (IAE) as existed in equation (13). $e(t)$ denotes the error value between output $Y(t)$ and set point r

$$f_{i,G} = IAE = \int_0^t |e(t)| dt \quad (13)$$

The objective function will move into the crossover step, as illustrated in Figure 5. Crossover recombines the set of parents which will be randomly selected from the first selection process once the population has been initialized. The individual selection process for crossover has a probability of 0.7. Results of the crossover process that are less than the preset probability will be sent to the mutation process.

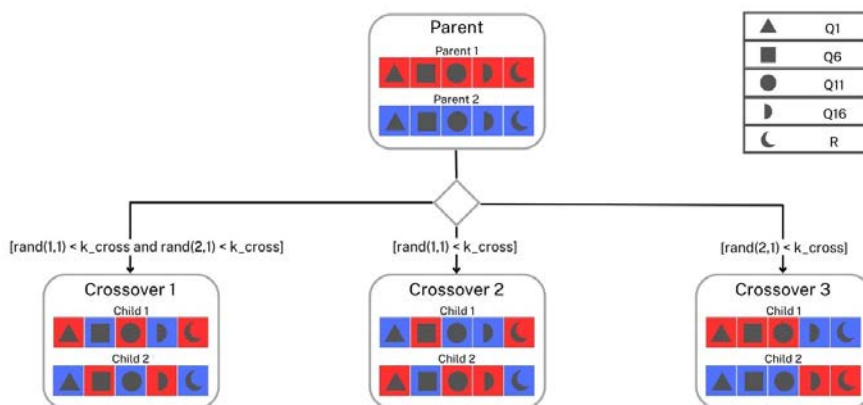

Figure 5. Crossover of genetic algorithms

Table 2. Genetic algorithm parameters

Parameter	Value
Population size	150
Crossover probability	0.7
Mutation probability	0.4
Maximum iteration	500

Similarly, the mutation process has a probability of 0.4 to select the candidate before it is regenerated. In its process, mutations make small changes in the individual by exchanging one or more genes in it with the opposite value. Mutations will occur if the individual has a probability of less than 0.4 and vice versa. Finally, the successfully mutated individuals will be regenerated, and they will re-enter the optimization process once it has not reached the fitness value.

Iteration is the main step in this optimization method. The iteration process is carried out 500 times starting from evaluating the fitness value until the method gets the best individual. The best generation can survive and move on to the next generation. The optimization method will continue until the fitness value is reached.

III. Results and Discussions

A. The determination of LQ parameter using manual tuning

The study involves five manual tuning experiments, focusing on the key parameters of LQ, namely Q and R which choose the best parameters' value based on the system's transient response. In the context of the Q matrix, manual tuning is specifically conducted on certain elements (Q1, Q6, Q11, and Q16) that reside along the diagonal of the matrix, as indicated in equation (8). The manual tuning process yields transient response graphs, presented in Figure 6 with the data listed in Table 3.

All the tests show that the LQ control method can eliminate steady state error, but when considering rise time and settling time, a higher value of the Q parameter compared to R results in a faster time. On the other hand, increasing the R value reduces the overshoot. In the initial test, the resulting overshoot value was too high when used in the

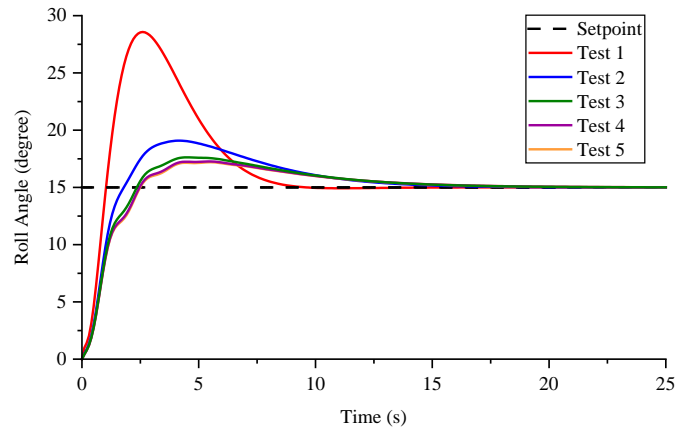

Figure 6. The graph transient response of five manual tuning

bicopter control system. Maintaining the R value while decreasing the Q value significantly can also lessen the overshoot. However, it is not enough since the overshoot value is still considered excessive at 27.2% (equivalent to 4.08°). After adding the R value in the remaining tests, the overshoot can fall off with around a 10% drop (equivalent to 1.5°) and more. However, the third test demonstrates superior performance compared to the other tests in terms of rise time, with 1.64 seconds, and settling time, with 14.33 seconds. As a result, this study sets the parameters utilizing the values from the third test, where $Q = 50$ and $R = 50$, as they exhibit a favorable transient response that satisfies the four specified criteria. These parameters are then used as a benchmark for comparing the optimization performance of LQ control with GA.

B. Genetic algorithms parameter optimization

To evaluate the effectiveness of GA in parameter optimization, it is crucial to observe the fluctuations in fitness value across generations. A proficient GA should demonstrate an upward trend in fitness values over time, never yielding a value lower than the fitness value of the preceding generation, ultimately reaching the highest fitness value in the final generation. The performance analysis of the GA

in this research can be discerned by referring to the fitness value graph depicted in Figure 7.

By employing GA, the initial generation obtains a fitness value of 3,162.7. Then it slightly increases until the 130th generation experiences a significant increase to more than 6,000. Further progress was observed in the 433rd generation, reaching more than 7,000. The final enhancement occurred in the last generation, with 7,447.17 in fitness value. These results demonstrate that GA has the capability to optimize the Q and R parameters in the bicopter control system based on the LQ approach.

The tests are conducted 20 times with the aim of assessing the repeatability and consistency of the GA to obtain the most optimum parameter for the controller. Table 4 shows the details of the 20 tests using GA. The result shows that the highest fitness value is 7,447.17. This value makes it the best candidate for LQ optimization with GA. Therefore, the best candidate can use the Q matrix parameters with Q1, Q6, Q11, and Q16 equal to 0.4, 47.97, 958.6, and 26.71, and R matrix equal to 1.34.

The result also provides the standard deviation and average of the obtained parameters' values. The smaller the standard deviation indicates good repeatability and consistency. In some of them, it shows low standard deviation, as seen in parameters

Table 3.
Performance of LQ control using manual tuning

Test	Q	R	Rise Time (s)	Settling Time (s)	Overshoot (%)	Steady State Error ($^\circ$ degree)
1	1,000	10	0.74	8.45	90.5	0
2	50	10	1.11	13.53	27.2	0
3	50	50	1.64	14.33	17.5	0
4	10	50	1.77	14.43	15.1	0
5	10	1,000	1.8	14.45	14.6	0

Table 4.
20 running tests of LQ control parameters with genetic algorithms optimization

Criteria	LQ Parameters									Fitness Value
	Q1	Q6	Q11	Q16	R	K1	K2	K3	K4	
Best result	0.40	47.97	958.60	26.71	1.34	1.65	4.95	18.09	2.49	7,447.17
Standard deviation	12.49	25.30	49.95	6.29	1.86	0.47	1.15	4.10	0.70	761.57
Average	12.24	26.86	954.84	10.37	5.79	1.01	1.88	6.35	0.48	5,276.44

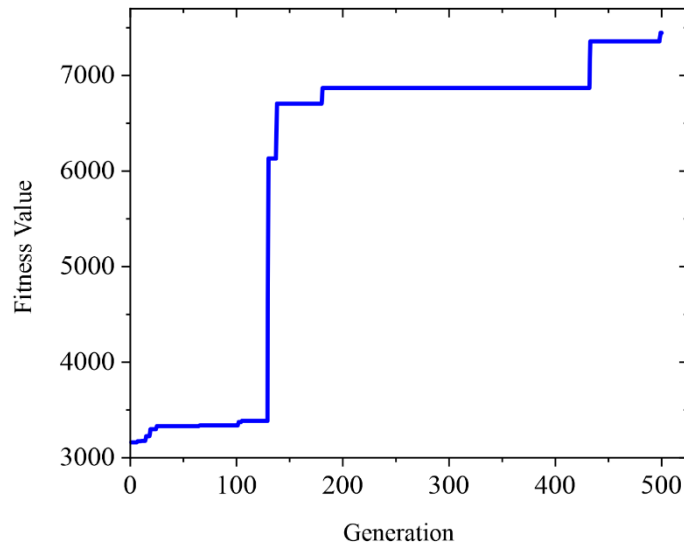
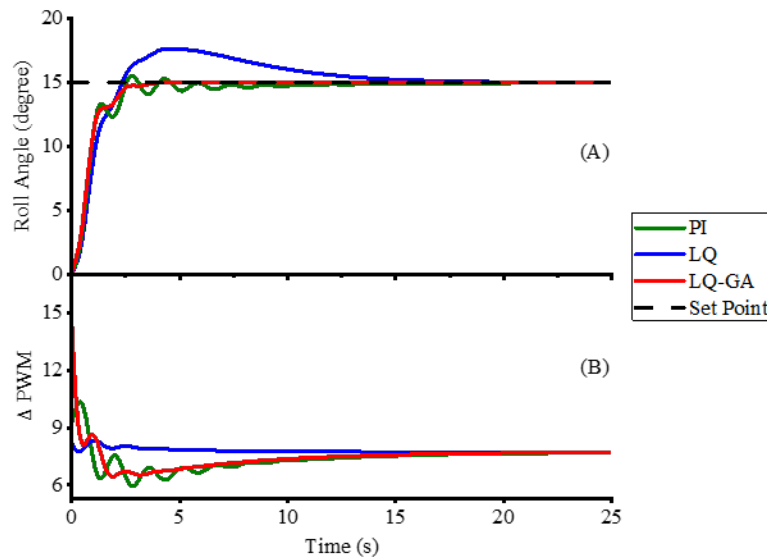

Figure 7. Graph of every generation's fitness value from genetic algorithm

Figure 8. (A) Transient response of PI, LQ, and LQ-GA roll angle and (B) transient response of PI, LQ, and LQ-GA ΔPWM

Q16, R, K1, K2, K3, and K4, while the others are considerably high. In terms of average, most parameters display significantly different values to the best result, except for Q11 and K1. These results reveal that based on the experiment, the employed GA can achieve the most optimum solution but the repeatability and consistency for several attempts are limited.

C. The comparison of PI, LQ, and LQ-GA

To assess the optimization performance of GA, the transient response between the system with LQ, LQ-GA, and PI-Controller tuned with the Ziegler-Nichols method [16] are compared. From the transient response graph in section (A) of Figure 8, it becomes evident that GA has achieved success in identifying optimal parameters. This success is indicated by the superior transient response of the LQ-GA method compared to the PI and LQ methods. Further details and comparisons can be found in Table 5.

Regarding rise time, the three methods are not significantly different, and the LQ method achieves the fastest rise time of 1.63 seconds. However, when considering settling time, notable differences emerge between the methods, with LQ-GA demonstrating superiority by achieving a settling time of 2.60 seconds. Similarly, in terms of maximum overshoot, LQ-GA outperforms both the PI and LQ methods, with a value of 0.17%. Moreover, all three methods could reach a zero steady-state error, indicating their effectiveness in adjusting the

Table 5.
Comparison of transient response of each controller

Criteria	Unit	PI	LQ	LQ-GA
Rise time	second (s)	1.96	1.64	1.74
Settling time	second (s)	8.34	14.33	2.60
Maximum overshoot	%	3.71	17.49	0.17
Steady state error	degree	0	0	0

bicopter angle to match the predetermined setpoint.

When analyzing the control signal graph, represented as ΔPWM , in section (B) of Figure 5, it validates that all three approaches generate signals within a realistic range of values suitable for controller devices with specifications of 8-bits or more because on 8-bits it can generate PWM signals up to 255 [31]. However, the PI and LQ exhibit graphs with rapid oscillations, potentially leading to unstable system performance. This instability arises from the inability of the device to cope with excessively fast changes in PWM signals. Furthermore, such rapid changes in current and voltage can increase the risk of device damage [32]. In contrast, the LQ-GA method produces a more stable control signal, making it safer to apply to controller and actuator devices.

On the other hand, considering the speed at which a system responds to reach the desired value, minimizing the settling time holds greater significance than reducing the rise time [33]. Although the rise time value on the LQ is slightly better than the LQ-GA, the settling time value on the latter is much faster than the former. Overall, LQ-GA can be considered a better control method than PI and LQ control concerning rise time, settling time, and maximum overshoot. As a result, the LQ-GA approach is deemed more suitable to be applied to balancing bicopter systems with non-zero set points, as it can effectively achieve a more stable system response.

IV. Conclusion

After conducting all the tests above, it can be inferred that LQ Control with GA results in more optimal performance for the balancing bicopter control with a non-zero setpoint. In comparison to PI and LQ controllers, the LQ-GA type demonstrates superior performance. It exhibits a faster settling time and smaller maximum overshoot and generates more stable control signals, which maintain the controller device and actuator safe. Additionally, the LQ controller produces worse settling time and maximum overshoot in the transient response compared to LQ-GA, despite obtaining the fastest rise time and shortest settling time. As for future development, researchers can consider the nonlinearity of the system in designing the controller. The next development can also be about increasing the repeatability and consistency performance of the genetic algorithm. Robust control or model predictive control could also be options for future works, despite the implementation of those methods is still very challenging.

Acknowledgements

We would like to express our sincere gratitude to the Faculty of Engineering, Universitas Negeri Semarang (UNNES) for supporting this work through a research grant with contract number 70.17.4/UN37/PPK.05/2023.

Declarations

Author contribution

E. Apriaskar: Writing - Original Draft, Review & Editing, Conceptualization, Investigation, Software, Resources, Formal analysis, Project administration, Supervision. D. Prastiyanto: Writing - Review & Editing, Project administration, Validation, Supervision. A.B. Utomo: Writing - Review & Editing, Validation. A.A. Manaf: Writing - Review & Editing, Software, Visualization, Data Curation, Resources. I. Amelia: Writing - Original Draft, Review & Editing. D.A. Ilham: Writing - Original Draft, Review & Editing, Visualization. V.L. Bilqis: Writing - Review & Editing. C. Photong: Writing - Review & Editing, Validation.

Funding statement

This research was funded by Faculty of Engineering, Universitas Negeri Semarang, Indonesia.

Competing interest

The authors declare that they have no known competing financial interests or personal relationships that could have appeared to influence the work reported in this paper.

Additional information

Reprints and permission: information is available at <https://mev.brin.go.id/>.

Publisher's Note: National Research and Innovation Agency (BRIN) remains neutral with regard to jurisdictional claims in published maps and institutional affiliations.

References

- [1] R. Z. B. Bravo, A. Leiras, and F. L. Cyrino Oliveira, "The Use of UAVs in Humanitarian Relief: An Application of POMDP-Based Methodology for Finding Victims," *Prod Oper Manag*, vol. 28, no. 2, pp. 421–440, Feb. 2019.
- [2] W. Sun, L. Dai, X. Zhang, P. Chang, and X. He, "RSOD: Real-time small object detection algorithm in UAV-based traffic monitoring," *Applied Intelligence*, vol. 52, no. 8, pp. 8448–8463, Jun. 2022.
- [3] P. S. Ramesh and J. V. M. L. Jeyan, "Comparative analysis of the impact of operating parameters on military and civil applications of mini unmanned aerial vehicle (UAV)," in *AIP Conference Proceedings*, American Institute of Physics Inc., Dec. 2020.
- [4] S. M. Shavarani, M. Golabi, and G. Izbirak, "A capacitated biobjective location problem with uniformly distributed demands in the UAV-supported delivery operation," *International Transactions in Operational Research*, vol. 28, no. 6, pp. 3220–3243, Nov. 2021.
- [5] R. S. Adarsh and M. M. Dharmana, "Multi-terrain Multi-utility robot," in *Procedia Computer Science*, Elsevier B.V., 2018, pp. 651–659.
- [6] O. B. Albayrak, Y. Ersan, A. S. Bağbaşı, A. T. Başaranoglu, and K. B. Arkan, "Design of a Robotic Bicopter," *7th International Conference on Control, Mechatronics and Automation (ICCMA)*, pp. 98–103, 2019.
- [7] E. Apriaskar, D. Prastiyanto, A. A. Manaf, I. Amelia, and Fahmizal, "Multi-criteria Genetic Algorithm Optimization Approach for Balancing Bicopter Control," *IOP Conf Ser Earth Environ Sci*, vol. 1203, no. 1, p. 012027, Jun. 2023.
- [8] S. Joksimovic, D. Ifenthaler, R. Marrone, M. De Laat, and G. Siemens, "Opportunities of artificial intelligence for supporting complex problem-solving: Findings from a scoping review," *Computers and Education: Artificial Intelligence*, vol. 4, p. 100138, 2023.
- [9] S. Bari, S. S. Zehra Hamdani, H. U. Khan, M. ur Rehman, and H. Khan, "Artificial Neural Network Based Self-Tuned PID Controller for Flight Control of Quadcopter," in *2019 International Conference on Engineering and Emerging Technologies (ICEET)*, IEEE, Feb. 2019, pp. 1–5.
- [10] A. A. Najm and I. K. Ibraheem, "Nonlinear PID controller design for a 6-DOF UAV quadrotor system," *Engineering Science and*

- Technology, an International Journal*, vol. 22, no. 4, pp. 1087–1097, Aug. 2019.
- [11] M. Tolba and B. Shirinzadeh, "Generic modeling and control of unbalanced multirotor UAVs," *Aerosp Sci Technol*, vol. 121, Feb. 2022.
- [12] A. Eltayeb, M. Fuaad Rahmat, M. Ariffanan, and M. Basri, "Adaptive Feedback Linearization Controller for Stabilization of Quadrotor UAV," *International Journal Of Integrated Engineering*, vol. 12, no. 4, pp. 1–17, 2020.
- [13] Q. Zhang, Z. Liu, J. Zhao, and S. Zhang, "Modeling and attitude control of Bi-copter," in *2016 IEEE International Conference on Aircraft Utility Systems (AUS)*, IEEE, Oct. Pp.172-176, 2016.
- [14] A. Bhaskar, G. Verma, and S. Sharma, "MARVEL: A High Pitch Agile Bi-copter Wall-Climbing Robot," in *Advances in Robotics - 5th International Conference of The Robotics Society*, New York, NY, USA: ACM, pp. 1–6, Jun. 2021.
- [15] Y. Qin, W. Xu, A. Lee, and F. Zhang, "Gemini: A Compact yet Efficient Bi-copter UAV for Indoor Applications," *IEEE Robot Autom Lett*, pp. 1–1, 2020.
- [16] E. Apriaskar, F. Fahmizal, N. A. Salim, and D. Prastiyanto, "Performance Evaluation of Balancing Bicopter using P, PI, and PID Controller," *Jurnal Teknik Elektro*, vol. 11, no. 2, pp. 44–49, Dec. 2019.
- [17] H. Al-Khazraji and L. T. Rasheed, "Performance Evaluation of Pole Placement and Linear Quadratic Regulator Strategies Designed for Mass-Spring-Damper System Based on Simulated Annealing and Ant Colony Optimization," *Journal of Engineering*, vol. 27, no. 11, pp. 15–31, Nov. 2021.
- [18] M. F. Shehzad, A. Bilal, and H. Ahmad, "Position & Attitude Control of an Aerial Robot (Quadrotor) With Intelligent PID and State feedback LQR Controller: A Comparative Approach," in *2019 16th International Bhurban Conference on Applied Sciences and Technology (IBCAST)*, IEEE, Jan. 2019, pp. 340–346.
- [19] K. Choutri, M. Lagha, L. Dala, and M. Lipatov, "Quadrotors UAVs Swarming Control Under Leader-Followers Formation," in *2018 22nd International Conference on System Theory, Control and Computing (ICSTCC)*, IEEE, Oct. 2018, pp. 794–799.
- [20] S. Bagheri, T. Jafarov, L. Freidovich, and N. Sepehri, "Beneficially combining LQR and PID to control longitudinal dynamics of a SmartFly UAV," in *2016 IEEE 7th Annual Information Technology, Electronics and Mobile Communication Conference (IEMCON)*, IEEE, Oct. 2016, pp. 1–6.
- [21] M. Taherinezhad, A. Ramirez-Serrano, and A. Abedini, "Robust Trajectory-Tracking for a Bi-Copter Drone Using INDI: A Gain Tuning Multi-Objective Approach," *Robotics*, vol. 11, no. 5, Oct. 2022.
- [22] J. A. Prakosa, H. Wang, E. Kurniawan, S. Agmal, and M. J. Kholili, "Experimental studies of linear quadratic regulator (LQR) cost matrices weighting to control an accurate take-off position of bicopter unmanned aerial vehicles (UAVs)," *Journal of Mechatronics, Electrical Power, and Vehicular Technology*, vol. 13, no. 2, pp. 101–112, 2022.
- [23] Y. Hu, Z. Sun, L. Cao, Y. Zhang, and P. Pan, "Optimization configuration of gas path sensors using a hybrid method based on tabu search artificial bee colony and improved genetic algorithm in turbofan engine," *Aerosp Sci Technol*, vol. 112, p. 106642, May 2021.
- [24] L. Liang, J. Yuan, S. Zhang, and P. Zhao, "Design a software real-time operation platform for wave piercing catamarans motion control using linear quadratic regulator based genetic algorithm," *PLoS One*, vol. 13, no. 4, p. e0196107, Apr. 2018.
- [25] E. Joelianto, D. Christian, and A. Samsi, "Swarm control of an unmanned quadrotor model with LQR weighting matrix optimization using genetic algorithm," *Journal of Mechatronics, Electrical Power, and Vehicular Technology*, vol. 11, no. 1, pp. 1–10, Jul. 2020.
- [26] X. Hu, H. Zou, and L. Wang, "Design of the Linear Quadratic Structure Based Predictive Functional Control for Industrial Processes Against Partial Actuator Failures Using GA Optimization," *Int J Control Autom Syst*, vol. 17, no. 3, pp. 597–605, Mar. 2019.
- [27] A. I. Abdulla and I. K. Mohammed, "Aircraft pitch control design using LQG controller based on genetic algorithm," *Telkomnika (Telecommunication Computing Electronics and Control)*, vol. 21, no. 2, pp. 409–417, Apr. 2023.
- [28] Fahmizal, M. Arrofiq, E. Apriaskar, and A. Mayub, "Rigorous Modelling Steps on Roll Movement of Balancing Bicopter using Multi-level Periodic Perturbation Signals," in *2019 6th International Conference on Instrumentation, Control, and Automation (ICA)*, IEEE, Jul. 2019, pp. 52–57.
- [29] Q. Xu, Z. Wang, and Z. Zhen, "Information fusion estimation-based path following control of quadrotor UAVs subjected to Gaussian random disturbance," *ISA Trans*, vol. 99, pp. 84–94, Apr. 2020.
- [30] S. Mirjalili, "Genetic Algorithm," In *Evolutionary Algorithms and Neural Networks. Studies in Computational Intelligence*, vol 780. Springer, Cham.2019, pp. 43–55.
- [31] A. K. Joseph, A. Bousbaine, and A. Fareha, "A Wireless communication system for a quadrotor helicopter," in *2018 53rd International Universities Power Engineering Conference (UPEC)*, IEEE, Sep. 2018, pp. 1–5.
- [32] D. D'Amato, J. Loncarski, V. G. Monopoli, F. Cupertino, L. P. Di Noia, and A. Del Pizzo, "Impact of PWM Voltage Waveforms in High-Speed Drives: A Survey on High-Frequency Motor Models and Partial Discharge Phenomenon," *Energies (Basel)*, vol. 15, no. 4, p. 1406, Feb. 2022.
- [33] H. Zhang, P. Wan, J. Geng, Z. Liu, and Z. Chen, "A Fast Transient Response Digital LDO with a TDC-Based Signal Converter," *Electronics (Basel)*, vol. 9, no. 1, p. 132, Jan. 2020.