

EVALUATION OF POTENTIAL USAGE OF INCREMENTAL-TYPE ROTARY ENCODER APPLICATION FOR ANGLE SENSING IN STEERING SYSTEM

By Sunarto Kaleg



1
**EVALUATION OF POTENTIAL USAGE OF INCREMENTAL-TYPE
ROTARY ENCODER APPLICATION FOR ANGLE SENSING
IN STEERING SYSTEM**

Sunarto Kale^{2*}, Aam Muharam^a, Muhammad Redho Kurnia^a, Abdul Hapid^a

^aResearch Centre for Electrical Power and Mechatronics, Indonesian Institute of Sciences
Komplek LIPI, Building 10, Basement, Jl. Cisitno No. 154D, Bandung, West Java, 40135 Indonesia

Received 30 October 2013; received in revised form 7 November 2014; accepted 10 November 2014
Published online 24 December 2014

1
Abstract

The main target of a steering system is that the driver can change vehicle trajectory in accordance with the desired direction. Power steering has become a standard feature in automobile. It provides assisting power when the driver turns the steering wheel. The well-known power steering types include; Hydraulic Power Steering (HPS), Electro - Hydraulic Power Steering (EHPS), and Electric Power Steering (EPS). EHPS or EPS uses an Electronic Control Unit (ECU), which is specific for each vehicle. The ECU should be able to regulate power of electric motor to provide corresponding assisting power for the steering wheel. Therefore, ECU requires input signals, one of which is vehicle wheel angle that can be indicated from the vehicle steering wheel angle. Incremental type of Rotary Encoder (RE) is used in steering angle sensor on a minibus. RE specification used was 60 pulses per rotation and the minibus steering transmission specification is 3.5 round of right wheel off angle to the left wheel off angle. So we get the RE angular resolution of 6° per pulse and 105 number of pulses to half of the steering transmission ratio. Repeatability then was tested against a steering angle counter module. Testing was done with a test cycle consisting 3 repetitions: condition center of the steering wheel, the steering wheel is turned to full right, then to the full left, then back to the right up to the steering wheel center. The results obtained were 2 pulses deviation, or equivalent to 12° of steering angle.

Keywords: vehicle steering system, rotary encoder, incremental, steering wheel angle, repeatability.

I. INTRODUCTION

Most of the vehicles that roam the city road are comprised of piloted vehicles such as cars, buses, and trucks. The trajectory is a three-dimensional or planar curve, determined by a guidance system controlled by a human pilot. The guidance system acts by exerting forces on the vehicle that are able to change its trajectory [1].

Steering system is constituted of several main components as described in Figure 1: steering wheel, steering column, and steering transmission [2]. The steering wheel must be designed such it can be easily controlled and allows firm grip. It is made from composite and plastic enabling comfort and firm grip. The power which generated by the steering wheel is distributed to the steering transmission component through the steering column. The column is precisely and several segments built such that its axis is not in line with that of the steering transmission. The

segments also contribute to the ergonomic steering wheel positioning. Steering transmission amplifies the power applied by the driver which will be transmitted to the vehicle's wheels.

The effect of the reduction gear varies with vehicle type. Suppose a sedan utilizes a steering system that exhibits steering transmission ratio of 16. This configuration should enable curving the car wheels angle of 40° for 1.7 rotations relative to the steering wheel center.

Two types of steering transmission are commonly used; rack-pinion type and screw-sector or re-circulating ball bearing type. The first type, as seen in Figure 2, is commonly used by passenger car or small cargo vehicle [2]. Its versatility is mainly contributed by its simple mechanism, and favorable mechanical efficiency due to relatively low gear friction [1]. The direction of the forces acting on the steering transmission is parallel to lateral axis relative to the vehicle. This force causes the driver-controlled wheel to have the same lateral forces acting on it as it was on the rest of the wheels. In

12
* Corresponding Author: Tel: +6222 2503055
E-mail: sunarto.kaleg@lipi.go.id



Figure 1. Steering system scheme on the main components that constitute it [2]

return, the driver's ability to react to different kinds of road condition greatly enhanced.

Figure 3 shows the screw and sector type of steering transmission [3]. This type commonly used in middle class vehicle up to heavy cargo due to its compact transmission design that allows spacious engine room. It is quite beneficial compared to the previous type which forces the transmission to be placed right at the wheel axis. This type of transmission is composed of screw shaft that acts as the trajectory of the ball bearing causing minimal friction which in return greatly increases the mechanical transmission efficiency. Despite these benefits, the driver may not be able to react accordingly as well as if the previous type was used. It is caused by the inability of the wheels to transfer the lateral force to the driver-controlled wheel. Steering torque originated from the driver-controlled wheel itself. However, the torque from the wheels cannot return to the driver-controlled wheel.

Power steering has become a standard feature in automotive. It provides assisting power when the driver turns the steering wheel. The well-known power steering types include; Hydraulic

Power Steering (HPS), Electro - Hydraulic Power Steering (EHPS), and Electric Power Steering (EPS). EHPS or EPS uses an Electronic Control Unit (ECU), which is specific for each vehicle.

Nowadays, HPS is commonly used in most vehicles. The energy source is originated from the hydraulic energy which is produced by the engine turned the fluid pump. Excessive power of the engine enables HPS to be able to be used properly in many situations. The fluid pump components and its tank is shown in Figure 4.

HPS was deeply researched due to the increasing needs on high fuel efficiency, and strict gas emission standard. At low engine rotation, the power produced by HPS is very low causing the steering wheel to be heavy when rotated especially for large curving angle. On the other hand, when the engine spins at high angular velocity, the necessary power needed to supply the fluid pump increases while the power needed to turn the steer decreases. Hence, marking the flaw of HPS which lies in energy efficiency [4]. In response to this matter, EHPS was developed. It enables controlled and adjustable fluid pump mechanism relative to the vehicle speed and condition. Its main component is electric motor

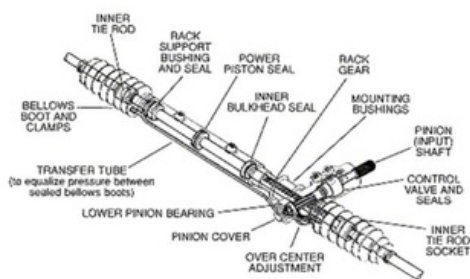

Figure 2. Rack and pinion-type steering transmission [2]

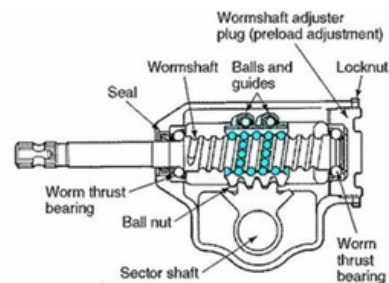

Figure 3. Screw and sector-type steering transmission [3]

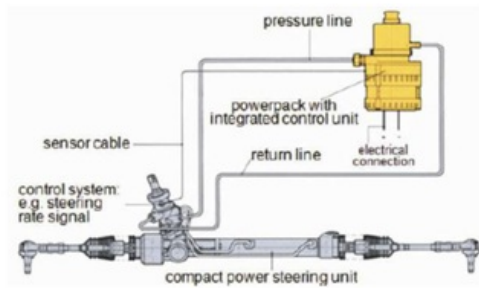

Figure 4. The scheme of electro-hydraulic power steering (EHPS) [5]

which is used to supply the fluid pump. The electronic control unit (ECU) controls the electric motor. The EHPS scheme is depicted in Figure 4.

Figure 4 also illustrates the ECU component which is integrated with the fluid pump [5]. The compact design enables the installation to be both flexible and integrated with steering transmission. Finally, the fluid used in either EHPS or HPS is the same thus allowing it to be used in all types of vehicles.

In EPS, an electric motor can be directly connected either to the axis of steering transmission or to the steering column. Figure 5 shows a column-type EPS [6]. It is noticeable that EPS is more compact than both HPS and EHPS. Furthermore, by utilizing a proper ECU, an EPS can produce the same power that is on par with both HPS and EHPS. Both EHPS and EPS use ECU which is specific for each types of vehicle. **1** In order to acquire suitable additional power, the ECU should be able to regulate the power produced by the electric motor. Several factors are used as inputs for ECU including

torque of the steering wheel, vehicle speed, angular speed of steering wheel, and wheels' angle [1]. The ECU in the EPS also uses the electric motor current as feedback signals to produce appropriate assisting power. However, when the power steering fails, such a steering system must allow a driver to take over manually.

EPS can independently design treatments of, for example, road surface information and disturbance information and steering safety and also can obtain safe, comfortable steering performance which is easily tunable has been proposed [7]. In line with Intelligent Transport System (ITS) trend, in the future, automatic controlled steering is predicted to be implemented [8-10].

Nowadays, absolute-type optical sensor, such as rotary encoder (RE), is commonly used. Absolute-type RE has an advantage in terms of the generated digital data that is ready to be processed. Methode Electronics released steering sensor which utilizes this type of sensor which has 1080° resolution [11]. Moreover, its sensitivity is about 1.5° , and has been equipped with a computer that is able to detect both steering angle and steering rotation speed. As shown in Figure 6, the light will go through combination of codes producing light patterns which will be sensed by the photocells. It will then be processed by the microprocessor whose result will be given to the ECU to regulate the response of electric motor according to the angle measurement.

Disadvantages of absolute-type RE are it requires many photocells to be mounted and aligned very precisely [12]. Other disadvantage is that the disk made with unequal

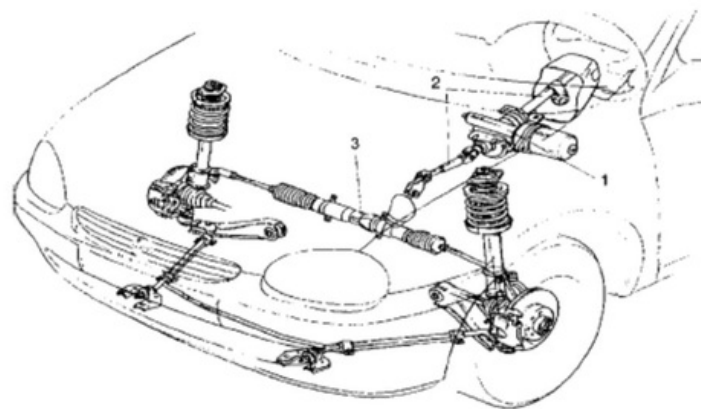

4

1. Steering column assembly
2. Steering column with intermediate spindle
3. Rack and pinion steering with external drive

Figure 5. Illustration on column-type EPS [6]

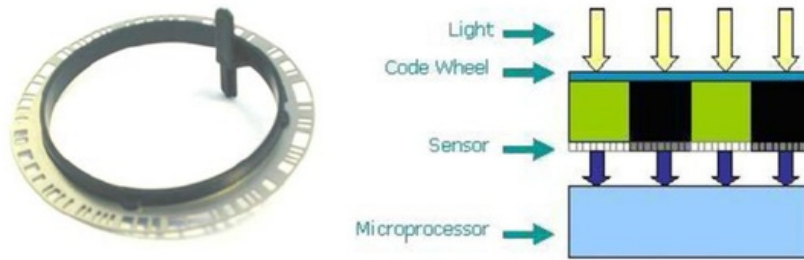

Figure 6. Steering sensor made by Methode Electronics [11]

spaced slots, make it expensive to be produced. The incremental-type RE has only one disk of equally spaced slots. Wheels' angle is determined by counting the number of slots that pass the photocells. This type RE only use two photocells for counting and convey the disk direction. So, it makes incremental-type RE cheaper than the absolute-type RE. This paper reports experiment results of angle sensor using incremental-type RE to investigate its possibility to be used as a steering angle sensor.

II. INCREMENTAL-TYPE ROTARY ENCODER AS ANGLE SENSOR

Autonics E80H is a hollow shaped incremental-type RE. This design, as shown in Figure 7, aims to connect to steering column without any transmission medium such as gear or pulley. The output is frequency of two waves, A and B, and one reference wave named Z. The shape of the superposition of the two waves is quadrature as shown in Figure 8 [13].

Pulse counter and direction determination are essential for RE to be able to be used as a steering angle sensor. As seen in Figure 9, direction can be determined by using two unique conditions of wave A relative to wave B. Suppose; an incremental-type RE has two waves namely A and B or V1 and V2. Hence, when V2

is low while V1 remains high, the direction is counter-clockwise. On the other hand, when both V1 and V2 are low, the direction is clockwise. The obtained direction can be combined with V2 through AND gate to count the pulse. The pulse increases when the RE axis is rotated clockwise, and decreases when rotated counter-clockwise [12]. The pulses counter flowchart is shown in the Figure 10, which is processed using microcontroller. Steering shaft position is counted from CW (count of pulse A in form of clockwise) and reduced by CCW (count of pulse A in form of counter-clockwise), then multiplied with RE resolution used.

III. ACCURACY AND REPEATABILITY

RE was characterized by its resolution rather by its calculation accuracy. It is able to accurately detect motion while limited by the quality of the rotation [14]. Suppose that an element deflection due to loading produces thread toleration of 0.1 inches. By using RE whose resolution is about 1,000 pulse per rotation, a reading of 0.001 inches can be read. However, it will never be able to read a movement of about 0.1 inches.

The accuracy of an RE in steering system is determined by the precise reading of the pulse against the curving angle. The accuracy limitation of the steering system is affected by



Figure 7. Incremental-type RE E80H released by Autonics [13]

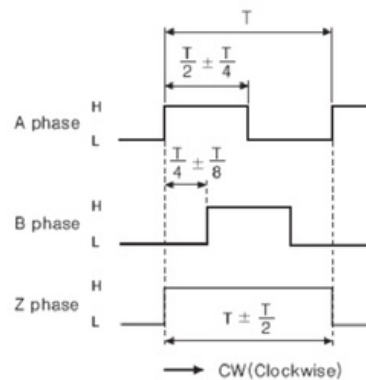

Figure 8. The output of the wave A, B, and Z [13]

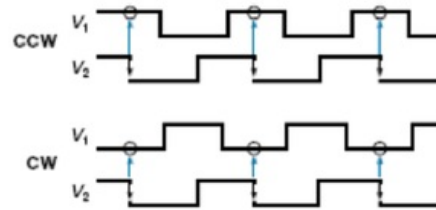

Figure 9. Direction determination through V1 and V2 processing [3]

tolerance value of the steering angle due to tolerances on mechanical components connections steering column, steering transmission and ball joint tolerance at the end of steering transmission with kingpins.

Repeatability is an RE ability to show the same value when rotated from the reference point to some point, and then back to the same reference point. In terms of steering system, the reference point is the center of the steer, and the wheels are positioned parallel to each other; enabling the vehicle to move in straight path. If rotated clockwise and counter-clockwise, then two curves in first quadrant and third quadrants will be obtained respectively. Figure 11 illustrates two curves in the first quadrant and third quadrant forming straight line bridging both quadrants. If the reference point is in the origin of the coordinate system (0, 0), then it is obvious that the ordinate will be negative to the left of the curve, and positive to the right of the curve. Repeatability is affected by the pulse deviation which is typically occurs in optical RE. This deviation is formulated as follows,

$$\text{Pulse deviation} = \text{Instrument error} + \text{Quadrature error} + \text{Interpolation error} + \text{Quantization error} \quad (1)$$

Instrument error is an eccentric code, wrong pattern, worn-out bearing, and optics flaws. Quadrature error is a combined effect of wave toleration, duty-cycle, and other variables in basic analog signals. Interpolation error is an error that occurs when the RE resolution raises after four calculations per optics cycle. Suppose, RE with resolution of 512 pulses per rotation was used for angle sensing. Then, the angle resolution would be 0.703125° per pulse. The computer will interpolate this value until the allowed rounding point which causes pulse increment. Quantization error is an error that is not originated from RE but will always occur in digital instrumentation [15]. Suppose we have digital number whose value is between 1 and 0, then this number must be quantized to either 1 or 0.

IV. RESULT ON INCREMENTAL-TYPE RE

This type of RE was used in the construction of steering sensor of 1 passenger car. The resolution of the RE is 60 pulses per rotation while the specification of the steering transmission is 3.5 rotations relative from the

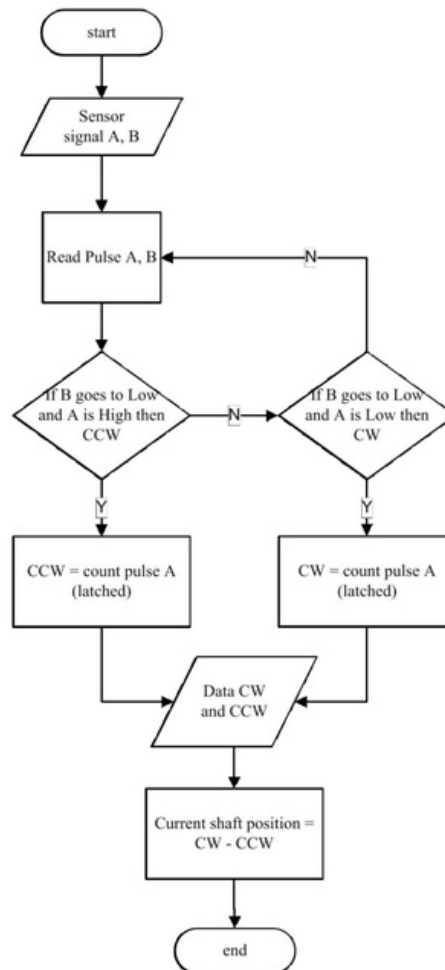

Figure 10. The flowchart process counting of steering shaft position

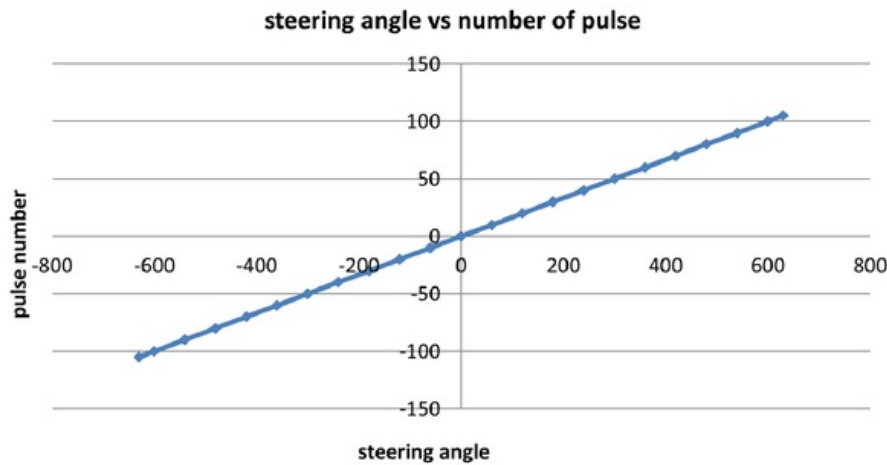

Figure 11. Relation between steering angle and number of pulses

fixed angle of the right to the fixed angle of the left. The resolution of the RE angle is formulated as follows,

$$\text{Angle Resolution} = \frac{360^\circ}{\text{Pulse resolution per rotation}} \quad (2)$$

Using equation (2), if specification of RE is 60 pulses per rotation, then the RE angle resolution is 6° per pulse. If the center of the steering wheel (the wheel facing straight forward) is half of the steering transmission ratio which is 0.75, then the number of pulses from the center of the steering wheel to the fixed angle of the wheels can be calculated using the formula,

$$\text{Number of pulses} = \text{RE resolution} \times \text{steering transmission ratio} \quad (3)$$

The generated pulse is 105 relative from the center of the steering wheel to the fixed axis of the wheels. One cycle of tests comprised of 3 repeats; from the center of steering wheel, it was turned to the all the way right, and the all the way to the left and then back to the initial position. Figure 12 shows the number of pulses within one cycle. The value is negative when the steer was turned left and positive when turned right. Data sampling was taken in every 30 degree of steering wheel angle. Then resulting total 133 data in one cycle. Count 5 pulse in every data theoretically.

From the tests, the relation between pulse deviation and number of tests was obtained as depicted in Figure 12. Figure 12 shows us that the highest pulse deviation is 2 pulses. The pulse

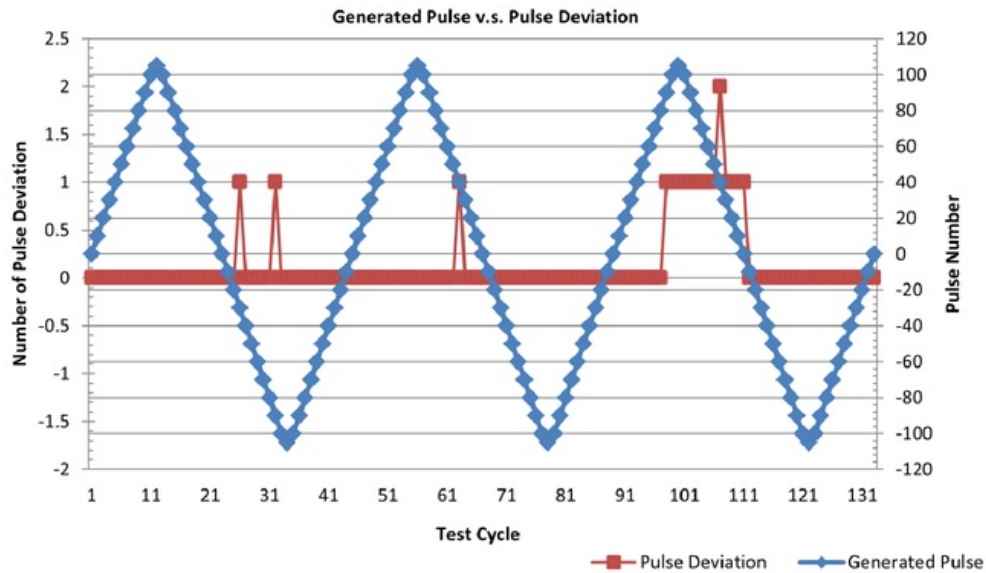

Figure 12. Generated pulses versus pulse deviation within one cycle

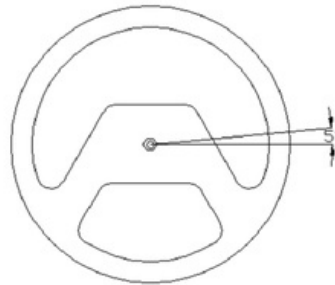

Figure 13. Toyota minibus steering angle tolerance measurement

deviation occurs in random data. It occurs when the encoder stops in the transition position i.e. position that does not generate one count. Then it one count is added to next data. Next, if the encoder stops in perfect position, there is no pulse deviation. The pulse deviation value can be converted to the actual angle deviation using the formula,

$$\text{angle deviation} = \text{pulse deviation} \times \text{angle resolution} \quad (4)$$

The angle deviation that occurred was 12° .

Figure 13 shows the value of steering angle tolerance is 5 degree. The angle deviation resulted by pulse deviation larger than permitted steering angle tolerance. These values will be used for developing methods to resolving RE signal conditioning, less pulse deviation, resulting less angle deviation. However, an RE which exhibits a much higher resolution to produce much smaller angle deviation produced, so that smaller angle deviation is can be used.

V. CONCLUSION

EHPS and EPS are additional power system for the steering wheel which uses specific ECU for each vehicle types. Power regulation of the electric motor is necessary to acquire the suitable additional power. One of the ECU inputs is the wheel's angle which can be sensed using optical sensor such as rotary encoder (RE). Among the types of RE, incremental type whose resolution is about 60 pulses per rotation was used. After repeatability tests, which comprised of 3 repeats; from the center of steering wheel, it was turned to the all the way right, and the all the way to the left and then back to the initial position. It produced pulse deviation of 2 pulses which equals to 12° of angle deviation. The angle deviation resulted by pulse deviation larger than permitted steering angle tolerance. These values will be used for developing methods to resolve RE signal conditioning, less pulse deviation, resulting less angle deviation.

REFERENCES

- [1] G. Genta and L. Morello, *The automotive chassis vol. 1*: Springer, 2009.
- [2] Tenneco Inc. (2011, 23 September). *Steering systems*. Available: <http://www.monroe.com.au/trade-corner/tech-info/suspension-systems/steering-systems.html>
- [3] Philippe. (2003, 23 September). *Steering system terms and how the system works*. Available: <http://www.imperialclub.com/Repair/Steering/terms.htm>
- [4] X. Chang-gao, et al., "Realization of control algorithm for electro-hydraulic power steering system based on M1008AW32 microcontroller," in *International Conference on Informatics, Cybernetics, and Computer Engineering (ICCE2011)*, Melbourne, Australia, 2011, pp. 581-589.
- [5] B. Heißing and M. Ersoy, *Chassis Handbook*, 1 ed.: Vieweg+Teubner, 2011.
- [6] D. A. Crolla, *Automotive Engineering*, 1 ed.: Butterworth-Heinemann, 2009.
- [7] S. Endo, et al., "Electric power steering apparatus control apparatus," Patent Number: US 20050103561 A1, 2005.
- [8] J. M. Armingol, et al., "IVVI: Intelligent vehicle based on visual information," *Robotics and Autonomous Systems*, vol. 55, pp. 904-916, 2007.
- [9] S. A. Birrell and M. S. Young, "The impact of smart driving aids on driving performance and driver distraction," *Transportation Research Part F: Traffic Psychology and Behaviour*, vol. 14, pp. 449-493, 2011.
- [10] V. Milanés, et al., "Intelligent automatic overtaking system using vision for vehicle detection," *Expert Systems with Applications*, vol. 39, pp. 3362-3373, 2012.
- [11] Methode Electronics Automotive Group Europe, "Steering angle sensor for automotive applications," ed: Methode Electronics, 2007, p. 1.

- [12] C. T. Killian, *Modern control technology: components and systems*, 2 ed.: Delmar, 2001.
- [13] Autonics Corporation. (2007, 7 Oktober). *E80H Series*. Available: http://id.autonics.com/products/products_detail.php?catecode=01/06/01&db_uid=63
- [14] Danaher Industrial Controls, *Encoder application handbook*. Gurnee, IL: Danaher Controls, 2003.
- [15] G. S. Gordon. (1998 – 2002, 7 October). *Let's talk accuracy*. Available: <http://www.gpi-encoders.com/>

EVALUATION OF POTENTIAL USAGE OF INCREMENTAL-TYPE ROTARY ENCODER APPLICATION FOR ANGLE SENSING IN STEERING SYSTEM

ORIGINALITY REPORT

19%

SIMILARITY INDEX

PRIMARY SOURCES

1	mevjournal.com Internet	345 words — 10%
2	www.mevjournal.com Internet	117 words — 3%
3	"Steering System", Mechanical Engineering Series, 2009 CrossCheck	31 words — 1%
4	www.scribd.com Internet	26 words — 1%
5	wrap.warwick.ac.uk Internet	25 words — 1%
6	rse.academia.edu Internet	21 words — 1%
7	140.116.207.88 Internet	19 words — 1%
8	Fernandez, Carlos, Raul Dominguez, David Fernandez-Llorca, Javier Alonso, and Miguel A.. "Autonomous Navigation and Obstacle Avoidance of a Micro-bus", International Journal of Advanced Robotic Systems, 2013. CrossCheck	16 words — < 1%
9	Xia Chang-gao. "Realization of Control Algorithm for Electro-Hydraulic Power Steering System	14 words — < 1%

10 spir.aoir.org 11 words — < 1%
Internet

11 Montazeri-Gh, Morteza, Zeinab Pourbafarani, and Hassan Nehzati. "Optimal Gear Ratio and Gear Shift Strategy Design for a Parallel Hybrid Electric Vehicle Equipped With AMT", ASME 2010 10th Biennial Conference on Engineering Systems Design and Analysis Volume 3, 2010. 11 words — < 1%
CrossCheck

12 Mirdanies, Midriem, Ary Setijadi Prihatmanto, and Estiko Rijanto. "Object Recognition System in Remote Controlled Weapon Station using SIFT and SURF Methods", Mechatronics Electrical Power and Vehicular Technology, 2013. 6 words — < 1%
CrossCheck

13 Saputra, Hendri Maja, Arif Santoso, Midriem Mirdanies, Vikita Windarwati, Riastus Nayanti, and Lukni Maulana. "Control of Pan-tilt Mechanism Angle using Position Matrix Method", Mechatronics Electrical Power and Vehicular Technology, 2013. 6 words — < 1%
CrossCheck